

## ***Protection for both rotary valve and bulk product***

Coperion, Weingarten, Germany, has recently launched the patented RotorCheck system for use with rotary valves. It is based on a monitoring device that detects any metallic contact between the rotor and the housing. This contact may result either from the presence of foreign particles or from a process malfunction, such as a sudden increase in product temperature, which may cause the rotor blades to expand and grate against the housing. Further causes may be a damaged bearing and incorrect installation and/or maintenance of the valve. In all these cases, the device not only prevents serious damage to the rotary valve itself, but also protects the product against contamination by metallic particles. It is approved for use in potentially explosive atmospheres. [www.coperion.com](http://www.coperion.com)

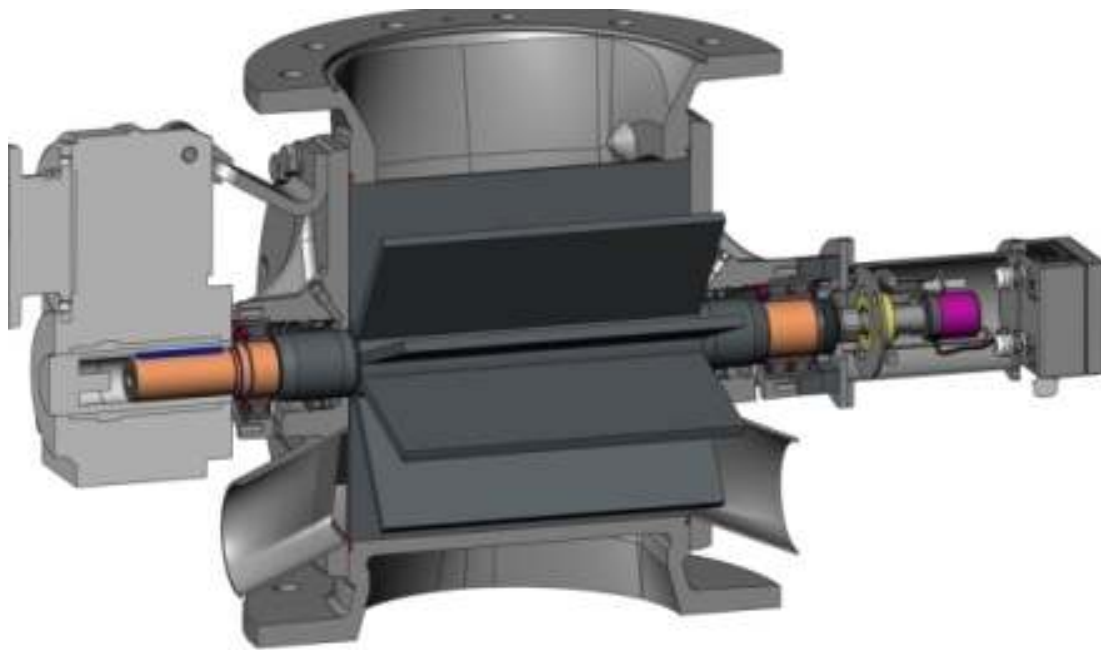

***Coperion's compactly built RotorCheck***